

ALLERGARD^{ES}

CONTAINMENT ANIMAL TRANSFER STATION

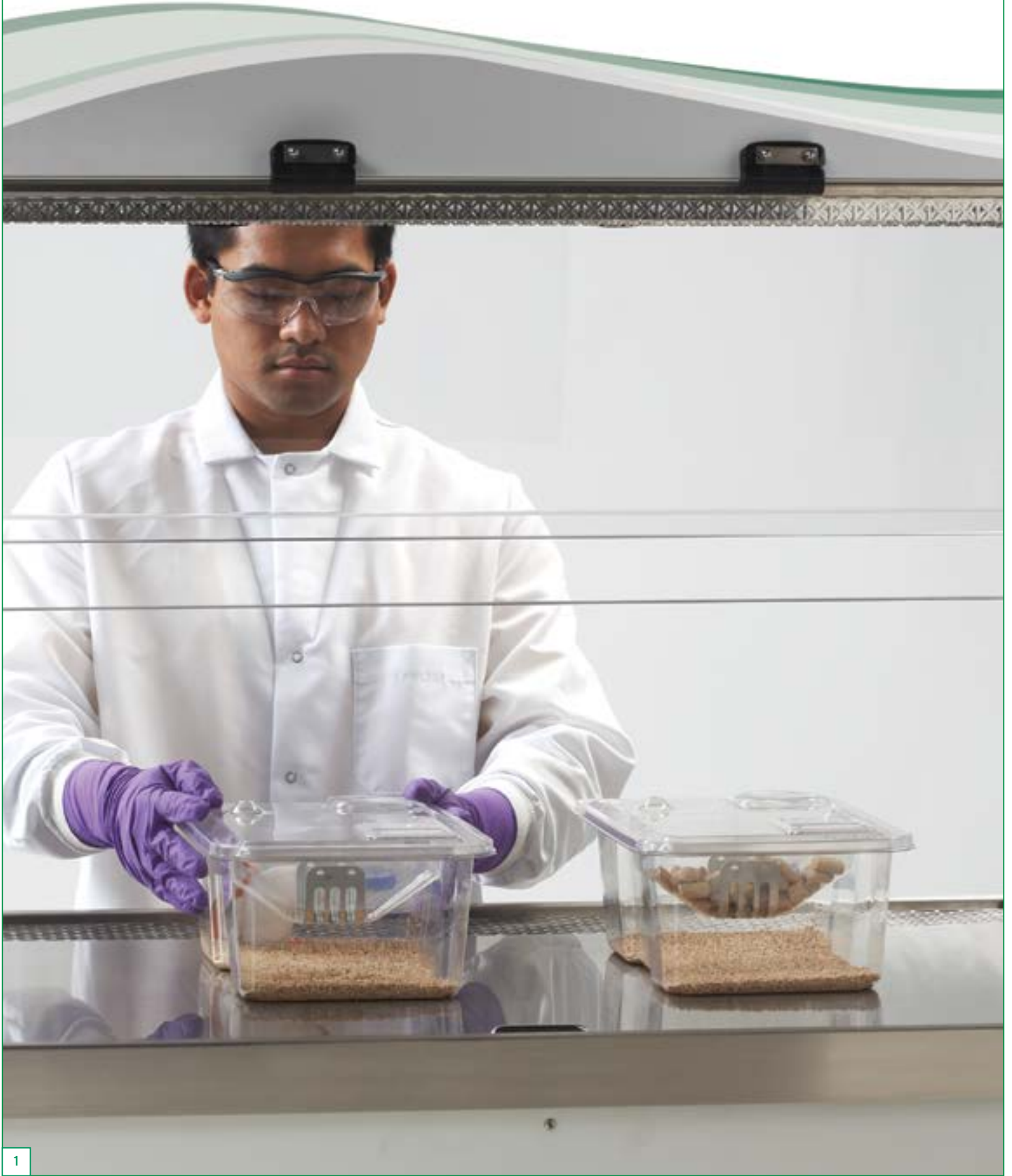



NuAire's AllerGard Small Animal Transfer Station model NU-620 provides ISO Class 3 sterility and protection for research animals.

The **AllerGard 620** is offered in 3 sizes and 2 distinct configurations. As a singled sided unit the NU-620 protects personnel by containing allergens shed by animals and bedding materials through an air barrier of 75 fpm (0.38 m/s) at the front of the cabinet and offers animal protection through

uniform down flow air at 60 fpm (0.30 m/s) minimizing cross contamination. As a dual sided cabinet the NU-620 maximizes usable space allowing access to the work zone from either side of the cabinet.



NU-620-400
Double-Sided Unit



NU-620-401
Single-Sided Unit

| Model | Width Size (nominal) | Configuration | Inflow | Downflow |
|------------|----------------------|---------------|-------------------|-------------------|
| NU-620-300 | 3.5 ft [1.1 m] | Dual Side | 25 fpm (0.13 m/s) | 60 fpm (0.30 m/s) |
| NU-620-400 | 4 ft [1.2 m] | Dual Side | 25 fpm (0.13 m/s) | 60 fpm (0.30 m/s) |
| NU-620-500 | 5 ft [1.5 m] | Dual Side | 25 fpm (0.13 m/s) | 60 fpm (0.30 m/s) |
| NU-620-301 | 3.5 ft [1.1 m] | Single Side | 75 fpm (0.38 m/s) | 60 fpm (0.30 m/s) |
| NU-620-401 | 4 ft [1.2 m] | Single Side | 75 fpm (0.38 m/s) | 60 fpm (0.30 m/s) |
| NU-620-501 | 5 ft [1.5 m] | Single Side | 75 fpm (0.38 m/s) | 60 fpm (0.30 m/s) |

Dual Side Access - Flexibility

The AllerGard NU-620-x00 Dual-Sided cabinet offers flexibility and correct user ergonomics

Dual Access Configuration

As a dual sided cabinet the AllerGard NU-620-x00 highlights ergonomic and work flow features designed into the cabinet. The mobile design allows multiple technicians to use the cabinet at the same time, or allows for easy access when moving the cabinet through cage aisles.



The AllerGard NU-620 can easily be moved by one technician, and fits through standard doorways.



An optional polycarbonate shield can be quickly installed without tools, enclosing either access of a dual-access AllerGard NU-620 allowing which allows it to function as a single-access unit.



NU-620-400
Double-Sided Unit

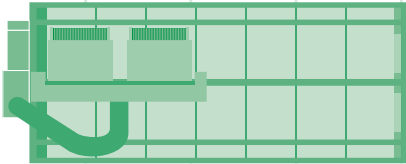
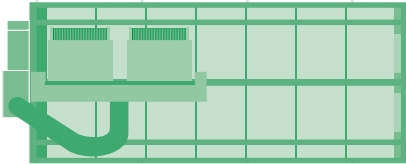
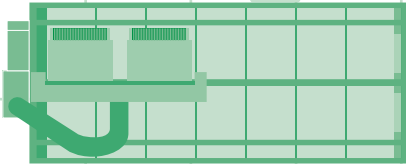
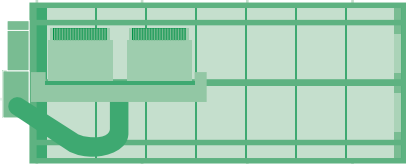
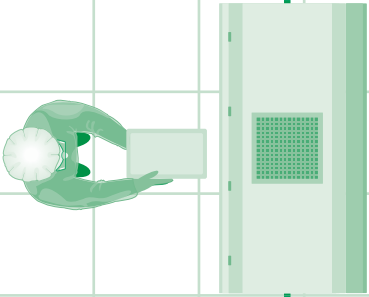
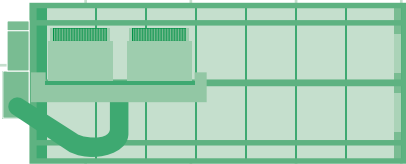
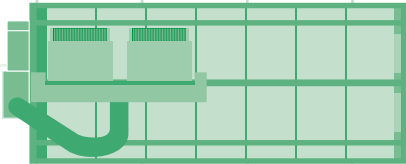
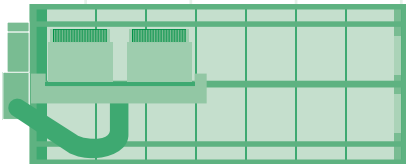
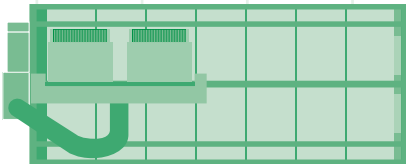

Single Side Access - High Containment

The AllerGard NU-620-x01 singled-sided cabinet is modeled after a Class II Biosafety Cabinet* offering personnel, product, and environmental protection through proper filtration and airflow.

Single Access Configuration

The rear of the cabinet is enclosed using a clear polycarbonate wall. **[A]** Side windows are lowered to maximize containment and product protection. **[B]** The work surface features perforated vacuum slots around the outer edges and back of the unit increases the airflow volume through the front work access opening. The work surface design along with a powerful exhaust motor allows 75 fpm (0.38 m/s) to move through the front access for improved product protection. Uniform down flow air flushes the work area and 60 fpm (0.30 m/s) and is pulled through the vacuum slots minimizing contamination maintaining animal sterility.

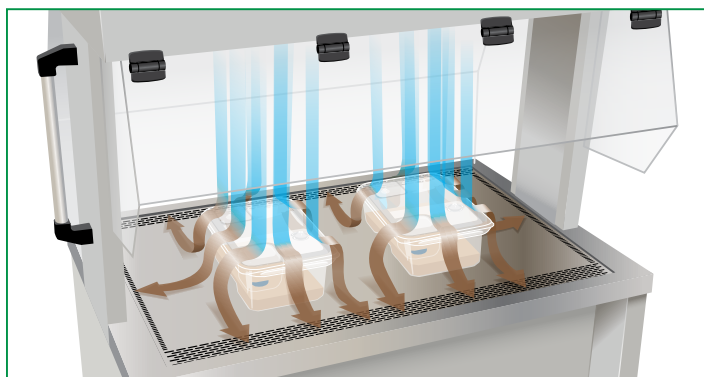

 HEPA-filtered Air

 Contaminated Air

* Disclaimer: NuAire Model NU-620 should NOT be used as a substitute for a Class II, Type A2 Biological Safety Cabinet. The NU-620 is not a containment device for airborne particulate in low to moderate risk-hazard research as prescribed by the CDC/NIH Biosafety in Microbiological and Biomedical Laboratories.

Single Pass Airflow Pattern Eliminates Work Zone Heat Buildup Placing Less Stress On Your Animals.

The airflow pattern starts with the supply pre-filter located on top of the station, continues through the supply Impeller and through the supply HEPA filter providing 99.99% particle removal at 0.3 microns. The airflow moves in a uniform vertical pattern providing particulate-free air in the work zone. The down flow air is then pulled into the vacuum slots around the work surface, through the exhaust pre-filters, and the exhaust HEPA filter.



- Room Air
- Pre-filtered Air
- Clean HEPA Filtered Air

Ergonomic Design



Ergonomic features that improve productivity while offering personnel exceptional comfort and convenience through many unique design features:

- A large work zone provides ample space for technicians to properly transfer animals from cage to cage.
- Electric auto-lift to adjust work surface height [12" (305 mm) range] at the touch of a button.
- Large 14" [356 mm] access opening height on all sides of the workstation.
- Zero heat build up in the work area. Over 25 air changes per minute in the work area.
- Proper cool white lighting from the top of the workstation improves visibility creating less eye strain.
- Easy-to-clean stainless steel plenum with waste disposal chute.



A Large 14" (356 mm) Access Opening makes it easy to add and remove the largest cages while providing your arms an extended range of motion.



A Spacious Work Zone offers more room to work with cages and allows for the additional placement of work flow items such as feed, water bottles, and more.



A large 12 inch (305 mm) slanted view screen provides an unrestricted view of the work zone allowing the technician to adequately and safely do their job.



Model NU-620 provides the ability to Sit or Stand at a Range of Heights through an automatic lift system offering 12-inches (305 mm) adjustable height.

AeroMax Electronic Control System

The AeroMax Electronic Control System (ECS) monitors and displays airflow system performance via PresurFlow™ - A specialized digital pressure transducer.

The AeroMax ECS features:

- Light Timer
- Warm-up mode
- Password Protection
- Audible and Visual Airflow Alarm
- Software updates via USB
- Software / hardware watchdog - automatically reset upon failure to last known status or to blower "ON" to assure containment.

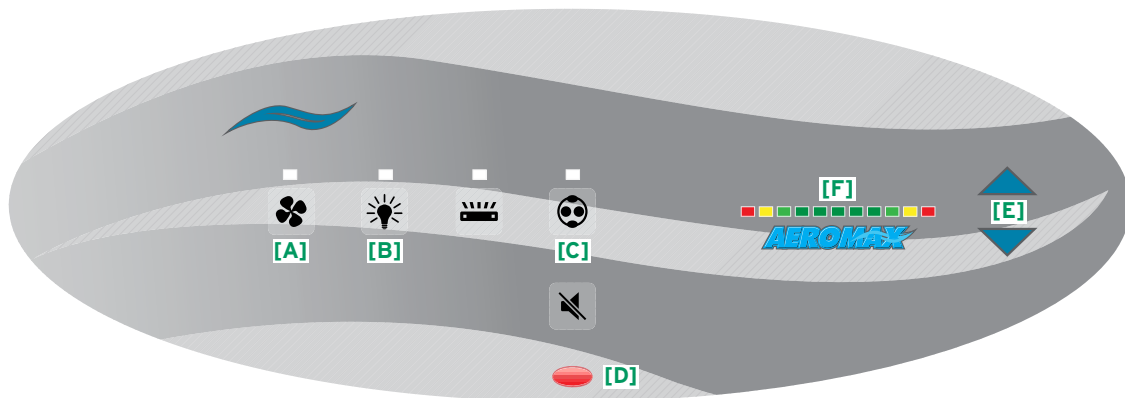

[A] The Blower key indicates and controls ON/OFF power to the blower.

[B] The Light key indicates and controls ON/OFF power to the fluorescent light.

[C] The Outlet key indicates and controls ON/OFF power to the outlets.

[D] The Red Alarm LED indicates any alarm condition.

[E] The Arrow Adjustment keys allow user interaction for various functions.

[F] Visual status alarm:

Green = Acceptable Pressure

Yellow = Caution, near alarm point

Red = Alarm Condition

AllerGard NU-620 Containment Animal Transfer Station

The AllerGard High Containment Animal Transfer Station can be configured as a dual sided unit (NU-620-x00) for maximize usability or as a single side unit (NU-620-x01) for maximum containment.

| Model | Width Size (nominal) | Electrical* (all sizes) | Configuration | Work Surface (W x D) in [mm] | Exterior Dimensions** (W x D) in [mm] | Net Weight |
|------------|----------------------|--|---------------|---|---|-----------------------|
| NU-620-300 | 3.5 ft [1.1 m] | 115 VAC / 60 Hz E: 230 VAC / 50 / 60 Hz | Dual Sided | 36 ⁵ / ₈ x 28 ¹ / ₄ [930 x 718] | 42 x 30 ⁵ / ₈ [1067 x 762] | 430 lbs [195 kg] |
| NU-620-400 | 4 ft [1.2 m] | | Dual Sided | 42 ⁵ / ₈ x 28 ¹ / ₄ [1083 x 718] | 48 x 30 ⁵ / ₈ [1219 x 762] | 460 lbs [209 kg] |
| NU-620-500 | 5 ft [1.5 m] | | Dual Sided | 54 ⁵ / ₈ x 28 ¹ / ₄ [1387 x 718] | 60 x 30 ⁵ / ₈ [1524 x 762] | 530 lbs [240 kg] |
| NU-620-301 | 3.5 ft [1.1 m] | | Single Side | 36 ⁵ / ₈ x 28 ¹ / ₄ [930 x 718] | 42 x 30 ⁵ / ₈ [1067 x 762] | 430 lbs [195 kg] |
| NU-620-401 | 4 ft [1.2 m] | | Single Side | 42 ⁵ / ₈ x 28 ¹ / ₄ [1083 x 718] | 48 x 30 ⁵ / ₈ [1219 x 762] | 460 lbs [209 kg] |
| NU-620-501 | 5 ft [1.5 m] | | Single Side | 54 ⁵ / ₈ x 28 ¹ / ₄ [1387 x 718] | 60 x 30 ⁵ / ₈ [1524 x 762] | 530 lbs [240 kg] |

* Specify model with appropriate letter suffix for electrical specification. "NU-620-300E" for 230 VAC / 50 Hz. ** Add 5" (127 mm) overall for push/pull bars.

Height (All Models)

| Castor Size in [mm] | Height Range in [mm] | Work Surface (H) in [mm] | Station Height (H) in [mm] |
|---------------------|----------------------|-----------------------------------|------------------------------------|
| 4 [102] | 12 [305] | 35 1/2 - 47 1/2 [902 - 1207] | 80 1/2 - 92 1/2 [2045 - 2426] |

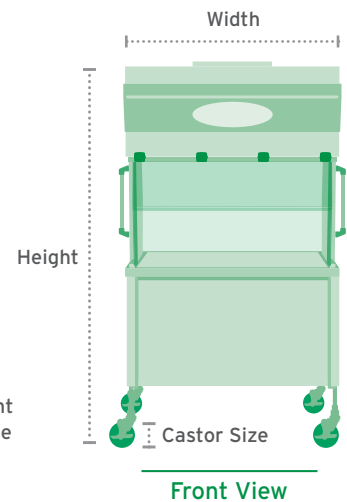
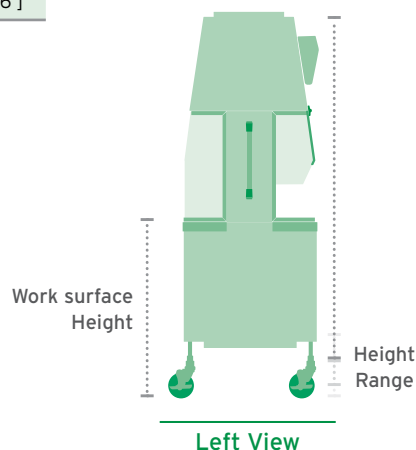
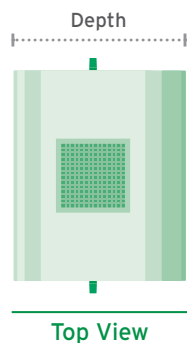

Performance Specifications:

NU-620-xx0 (Dual Sided)

25 fpm (0.13 m/s) Inflow
60 fpm (0.30 m/s) Down Flow

NU-620-xx1 (Single Sided)

75 fpm (0.38 m/s) Inflow
60 fpm (0.30 m/s) Down Flow

Standard Features:

- AeroMax Electronic Control System
- Ultra High Efficiency DC/ECM Motor
- Ultra High Efficiency EC Impeller
- Attenuumont Vibration Control System
- 76 mm (3") Metal Frame Supply HEPA Filter
99.99% @ 0.3 microns
- 76 mm (3") Metal Frame Exhaust HEPA Filter
99.99% @ 0.3 microns
- Washable/reusable exhaust pre-filter
- Washable/reusable supply pre-filter
- Metal Diffuser Over Supply Filter
- 14" (356 mm) Hinged Window Sash Access Opening**
- LED Lighting
- Light Timer
- 4" (102 mm) Castors w/ Brakes
- Two (2) Push/Pull Bars
- Removable Prop Up Work Tray
- Spill Trough with Waste Chute
- One (1) Duplex Outlet Right Side Wall
- 25 ft [7.6 m] Cord Reel

Optional Features and Accessories*:

- Disposable exhaust pre-filter
- Disposable supply pre-filter
- Feed Hopper (Left, Right, Dual)
- Magnifying Glass Window
- Stainless Steel Folding Shelf
- Hand Sanitizer
- Duplex Outlets
- GFI Duplex Outlets
- Adjustable Footrest

Custom Solutions

- Edstrom Watering Systems
- Red Light

** Note: some optional features are not approved by 3rd party listings. Please contact NuAir information.*



NU-620-400
Double-Sided Unit



NU-620-401
Single-Sided Unit

■ Green Ecological Features

| | |
|------------------|-----------------------|
| 3 YEAR | WARRANTY |
| | PARTS + LABOR |
| | United States, Canada |

| | |
|------------------|-----------------|
| 4 YEAR | WARRANTY |
| | PARTS |
| | Worldwide |

Design Your Own AllerGard NU-620

Popular Built-in Options & Accessories

Each vivarium is unique, and work flow processes can differ. Set your laboratory up for success by designing your own NuAire Animal Transfer Station. It can be as simple as adding a shelf or as involved as customizing the height of the work zone. NuAire can do it all. Invest in a product that lasts and is designed for your needs.



Folding Shelf



Cage Top Holder



Hand Sanitizer



Magnifying Glass



Feed Hopper



Bottle Rack



Base Stand Shelf

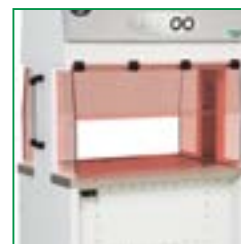

Red Light



Complete your Laboratory

NuAire offers a variety of Laboratory Equipment to meet the needs of the research, vivarium, pharmacy, environmental laboratory and more. Join the NuAire family and complete your laboratory with complementary NuAire Quality products.



LABGARD

Biosafety Cabinets



IN-VITROCELL

CO₂ Incubators



NUWIND

Centrifuges



Koki

CENTRIFUGES



Mini-Centrifuges



BLIZZARD

Ultralow Freezers



AIRGARD

Laminar Airflow Workstations



PHARMAGARD

Compounding Isolators



ALLERGARD

Animal Laboratory Products



**Polypropylene Fume Hoods
and Casework**



Custom Solutions

Delivering product to the customer that is cost effective, exceeds their requirements, delivers product on-time, and increases productivity and profitability.

In every NuAire product you'll find brilliant but practical design, keen attention to detail in every phase of the fabrication and assembly process, thoroughly tested, outstanding value, and dependable service. These are the foundation for NuAire's international reputation, and practical reasons why NuAire is universally recognized as the finest. NuAire's Quality Policy to Satisfy Customers, Comply with Quality System Requirements and Continually Improve.

Sales and Service Like No Other NuAire employs a network of knowledgeable sales and service individuals some of which have been selling and servicing NuAire Laboratory Products since our inception in 1971.

Our Sales Representatives are located throughout the globe providing you with a local individual who can assist product selection, pricing, installation, training, and service throughout the life of your product. Once you buy a NuAire you're a part of our family and we'll work hard to satisfy your needs.

NuAire offers service-training classes and individualize assistance to service professionals in the laboratory community. These NuAire certified companies are located throughout the world allowing NuAire to provide service and assistance to the farthest corners of the earth. Have the option to select from multiple service vendors in your area to find a company that fits your needs.

Contracts, GPO's and many more! NuAire has a variety of Contracts set up through Group Purchasing Organizations, Government Associations, Health Systems, Universities and many more.



Your Local NuAire Partner



For more information please visit
www.nuaire.com or call **1.763.553.1270**

SHARE A PICTURE AND TAG YOUR NUAIRE USING #MYNUAIRE

