



LABGARD[®] ES LP

NU-640 CLASS II TYPE A2 ANIMAL HANDLING BIOSAFETY CABINET

Big Cage? Small Lab? No Problem.

The LabGard[®] ES LP (Low Profile) NU-640 Class II, Type A2 Animal Handling Biosafety Cabinet provides the largest work access opening with the smallest footprint while offering enough versatility to assist with all facets in the vivarium industry. 105 fpm [0.53 m/s] in-flow combined with 60 fpm [0.30 m/s] true laminar down-flow creates the dynamic air barrier. The nominal 6 foot [1.8 m] wide cabinet allows the ability to mix and match an assortment of configurations. Combine Refuse Disposal with Dirty Cage Collection to create your perfect animal waste station.



environmental,
product & personnel
protection

Standard Features:

- Single Mesh Pre-Filter, Easy to Remove, Clean, and Reuse
- 14" [356 mm] Hinged Access Opening, Easily Fits Rat Cages
- Superior Ergonomics, Comfortably Reach In & Around Work Zone
- Motorized Auto-Lift Base Stand with Built-In Footrest
- Work Surface Height Range of 35" to 43" [889 to 1092 mm]
- Work Tray Prop-Up Bar for Easy Cleanability
- Low Profile; Compatible with Low-Hanging Ceilings
- AeroMax™ Control Center with Airflow Monitor & Audible Alarm
- 250% HEPA Filter Loading Capacity (≈10 Year Lifespan)
- 5 Year Parts, Labor, and Filter Warranty (US & Canada Only)
- 5" [127 mm] Heavy-Duty Casters for Extra Mobility
- ISO Class 5 Air Protection

Fits Through Standard Doorways

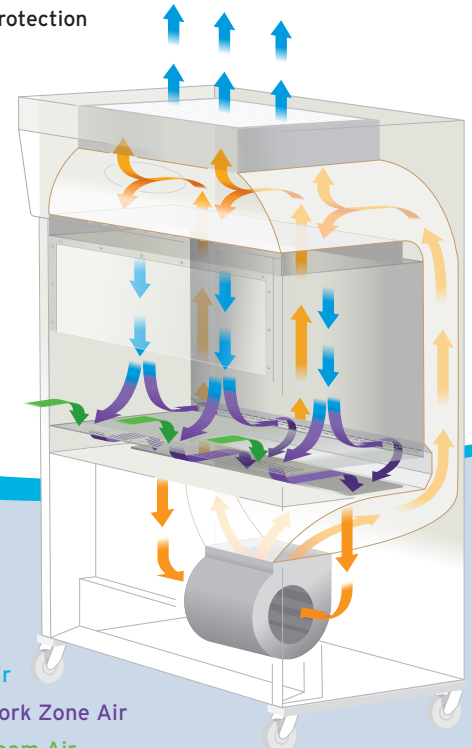
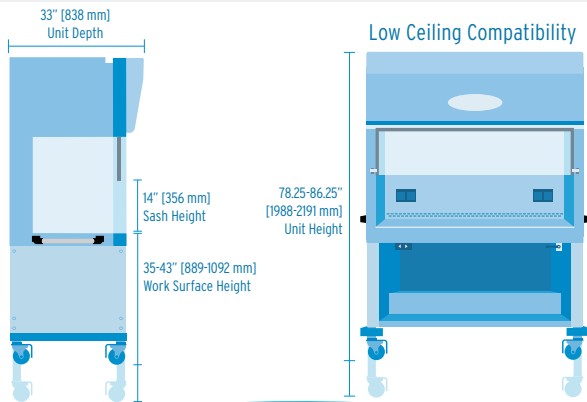

Work Tray Prop-up Bar & Fabric Mesh Pre-filter



14" [356 mm] Hinged Access Opening

- ➡ HEPA Filtered Air
- ➡ Contaminated Work Zone Air
- ➡ Contaminated Room Air
- ➡ Pre-filtered Work Zone Air

NU-640 Specifications

Class, Type, Style	Class II, Type A2, Console		
Model #	NU-640-400	NU-640-500	NU-640-600
Nominal Widths	4 ft [1.2 m]	5 ft [1.5 m]	6 ft [1.8 m]
Work Zone Dimensions (W x D x H)	46.5 x 22.75 x 24.625 in [1181 x 578 x 626 mm]	58.5 x 22.75 x 24.625 in [1486 x 578 x 626 mm]	70.5 x 22.75 x 24.625 in [1791 x 578 x 626 mm]
Exterior Dimensions (W x D x H)	56.375 x 33 x (78.25-86.25) in [1433 x 838 x (1987-2190) mm]	68.375 x 33 x (78.25-86.25) in [1737 x 838 x (1987-2190) mm]	80.375 x 33 x (78.25-86.25) in [2042 x 838 x (1987-2190) mm]
Net Weight	560 lbs [254 kg]	650 lbs [295 kg]	740 lbs [336 kg]
Certifications	UL listed, CE		
Access Opening / Type	14 in [356 mm] (Hinged)		
Electrical	115 VAC / 60 Hz		
Filter Load Capacity	250%		
Airflow	105 fpm [0.53 m/s] Dynamic In-Flow, 60 fpm [0.30 m/s] True Laminar Down Flow		
	ISO Class 5 Air Protection		
Supply Filter	3 in [76 mm] HEPA 99.99% Efficient @ 0.3 microns		
Pre-Filter	Animal Hair / Dander Pre-Filter		
Exhaust Filter	6 in [152 mm] HEPA 99.99% Efficient @ 0.3 microns		
Control System	Aeromax™ w/ PressureFlow™ Pressure Sensor		
Lighting	LED		
Password Protection	Yes		
Noise Level	Up to 67 dba		
Construction Options	Coved Interior Corners		
	Two (2) GFCI Duplex Outlets (Back Wall)		
	Removable Stainless Steel Easy-to-Clean Prop-Up Flat Work Tray		
	Side-Mounted Pull Bars		
	Up to Four (4) Service Valves/Couplings (Right/Left Sidewalls)		
	Attachable Armrest (Heavy-Duty Plastic or Stainless Steel)		
	16/18 gauge Stainless Steel Welded Construction		
	Stainless Steel Spill Trough w/ Drain Valve		
	AttenuMont™ Vibration Control Support System		
	Permanent Positive Pressure Plenum w/ Quick Release Supply Filter Removal		
	Customized Dirty Cage Collection Bin w/ Exterior Sidewall Mounted Shelf		
Integral Base Stand	Customized Heated Work Surface		
	Customized Waste Disposal System		
	Motorized Adjustable Base Stand w/ Built-In Footrest		
	Exhaust Canopy		
Popular Accessories	Butterfly Dampeners		
	Flex Duct		
	Cushioned Movable Elbow Rests		
Standard Feature		Optional Feature	



To Learn More or Request a Quote:

Visit: www.NuAire.com

or Call: 1-763-553-1270

Toll Free: 1-800-328-3352

